

Scattering imaging to measure size and velocity of small particles in dense particle systems

by

R. Calabria⁽¹⁾ and P. Massoli⁽²⁾

Istituto Motori - CNR
Via Marconi 8, 80125 Napoli, Italy
⁽¹⁾E-Mail: r.calabria@im.cnr.it
⁽²⁾E-Mail: p.massoli@im.cnr.it

ABSTRACT

A new scheme for GSI out-of-focus technique able to simultaneously measure size and velocity of droplets is presented and the basic principles discussed. The new approach, GSI-V, is based on a single CCD and a double laser pulse with crossed polarization. In the proposed system a slit is used in front of the detection optics to reduce large circular out-of-focus images to thin strings. This, together with the crossed polarizations of the laser pulses, permit the application of GSI-V to moderately dense droplets systems. Measurements of size and velocity of droplets in a calibrate spray of water are reported. A theoretical analysis concerning the application of the out-of-focus method to small droplets is also outlined. In dedicated experiments GSI approach was applied successfully to binary evaporating droplets as small as $7 \mu\text{m}$.

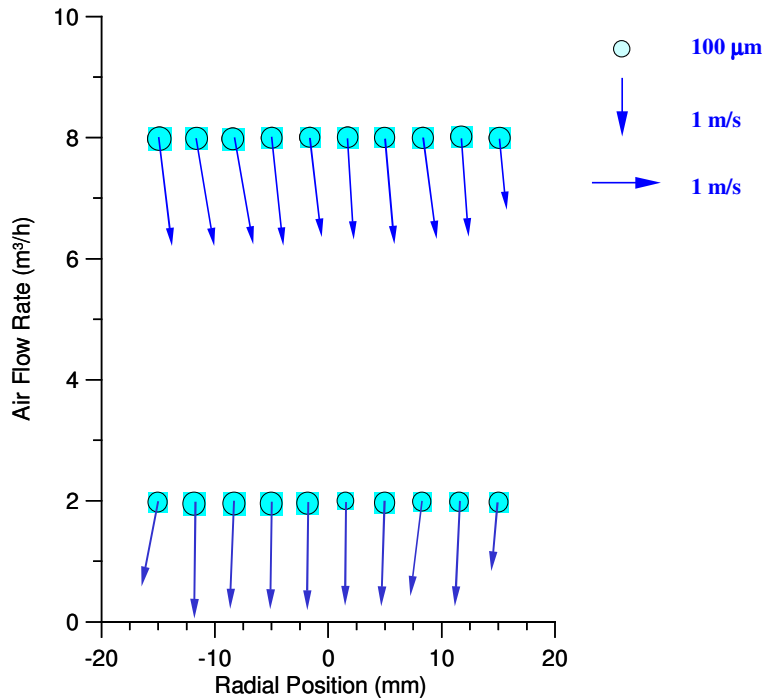

Fig.1. Mean droplets velocities and diameters measured by using GSI-V technique in a downstream water spray for two secondary coaxial flow rates. Zero radial position corresponds to the spray axis. The reported values represent the average of the vector droplet velocities and diameters measured on spatial regions $4\text{mm} \times 2\text{mm}$ ($W \times H$) at the exit of the tubular confining section.

1. INTRODUCTION

The light scattered by a spherical particle is characterized in the far field by strong oscillations which angular spacing and position depend on the properties of the particle, on the light wavelength and on the scattering angle (Kerker, 1969). Thus, the position and spacing of oscillations in the scattering pattern represent a univocal signature of the particle in the scattering volume (Bartholdi, 1980). This approach was also largely used to characterize droplets and permits high accuracy measurements (see the review in the book of Davis and Schweiger, 2002, and papers there cited; König et al., 1985, Min and Gomez, 1996). Nevertheless, if more particles are in the probe volume, the global scattering pattern in the far field is given by the superimposition of the fields scattered by every particle. In such a case, the identification of the angular pattern due to different particles is difficult and, hence, the analysis of the location of oscillations for every particle is prevented. Thus, the classical approach is able in practice to characterize a single droplet at time in a single spatial location and, hence, not suitable for 2-D particle measurements.

Ragucci et al. (1990), proposing the out-of-focus approach, opened the way to the 2-D utilisation of the optical particle characterisation method based on the analysis of the angular scattering pattern. They demonstrated that positioning the imaging system in out of focus, the interior of each defocused droplet picture is the image of the field scattered by the droplet itself. Then, by using the Lorenz-Mie theory, a correlation between drop diameter and number of oscillations per degree was found and size of droplets were measured by counting the number of oscillations present in each defocused drop image. Ragucci et al. (1990) used the Lorenz-Mie theory in the reduction of the experimental data in order to overcome limitations due to the use of geometrical optics relations. Therefore the method was called *Mie Scattering Imaging*. By using the out-of-focus approach the problem of acquiring on the same 2-D picture the far field scattered by different droplets was solved. In fact, in out-of-focus the field scattered by every droplet remains contained in its defocused image and more defocused droplets images can be acquired in a 2-D picture (Fig. 1). Applications of the out-of-focus approach can be found in Glover et al. (1995), Pajot and Mounaïm-Rousselle (1998), Calabria and Massoli (2000), Kobayashi et al. (2000), Koch et al. (2001), Krüger and Grünfeld (2001), Damaschke et al. (2002), Grassman and Peters (2003).

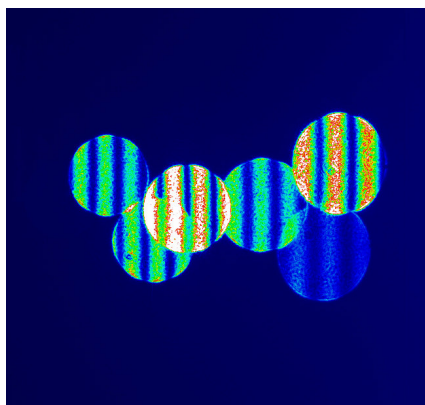

Fig.1 Out-of-focus image of 11 μm tetradecane droplets

Excluding very controlled cases or lab studies, in real applications droplets change markedly composition and temperature during their life. Droplet composition and temperature are related to the complex refractive index, $m = n - ik$, of the droplet. Thus, the angular pattern of droplets in practical applications will change with droplet evolution. As a consequence, also the angular spacing $\Delta\vartheta$ between intensity oscillations will be function of the droplet state. In order to study with high accuracy droplets in non-stationary sprays the influence of the refractive index have be taken into account. To overcome this problem the *Generalised Scattering Imaging*, GSI, out-of-focus technique was introduced (Massoli and Calabria, 1999; Calabria and Massoli 2000). It was theoretically assessed and experimentally verified that also for a large variation of the complex refractive index ($n= 1.2-1.7$; $k=10^{-6}-10^{-1}$) the spacing between angular oscillations remains extremely regular and his dependence on the refraction index was extremely limited at a scattering angle $\vartheta=60^\circ$. More interesting, it was found that at $\vartheta= 60^\circ$ a very simple relation relates the oscillation angular spacing and droplet diameter for both homogeneous or radially inhomogeneous droplets:

$$\Delta\vartheta (\vartheta, m(r), D) = 1.129 (180^\circ / \alpha) \quad \text{at } \vartheta = 60^\circ \quad (1)$$

where α is the non dimensional scattering parameter, $\alpha=\pi D/\lambda$. The slight residual dependence of $\Delta\theta$ on the refractive index results in a sizing uncertainty of about 4% when the refractive index span the maximum variation, i.e., from 1.3 to 1.7 (Massoli and Calabria, 1999). For limited variation of the refractive index, the uncertainty proportionally reduces. In GSI approach, the size of a droplet is inferred independently of droplets composition and temperature, by measuring the angular spacing of intensity oscillations of the scattered light in defocused droplet images and by using the previous relation (1). Thus, GSI technique is particularly suitable to study droplets in non-stationary regimes. GSI was applied to study droplets in evaporating (Calabria and Massoli, 2000) and combustion regimes (Calabria et al., 2003a) as well as in cooling conditions (Calabria et al., 2004).

In addition to variations of droplets properties typically encountered in practical applications, the droplets concentration is the other major limitation that has to be taken in consideration in case of techniques for spray analysis that are devoted to droplet image identification. A high droplets concentration prevents a good recognition of droplet images and drastically decreases the signal to noise ratio. In the out-of-focus approach, the superimposition of defocused images corresponds to the interference between the fields scattered by different droplets. This causes lower counting rates and can also prevent the identification of the angular pattern due to different particles and, hence, the analysis of the location of oscillations for every particle. Essentially, three different cases can be enumerated. The first one is related to the saturation of the imaging detector that can be reached when more droplets superimpose their scattering pattern. The second case happens when the fields scattered by more particles interfere to generate a complex scattering pattern; also in this case information is lost. In the third case no saturation happens and no complex pattern appears but, in any case, the image analysis is problematical. To overcome the limitation due to images superimposition, an experimental layout where droplet images are reduced to a string by means an optical compressor was proposed by Kobayashi et al. (2000). This scheme has the worth of measuring the velocity of droplet too. An integrated phase Doppler/out-of-focus imaging scheme was also proposed to simultaneously measure droplets size and velocity by Damaschke et al. (2002).

In this paper a new experimental scheme recently proposed for GSI technique to measure simultaneously size and velocity of droplets is presented (Calabria et al., 2003b). The experimental set up makes use of a single imaging system placed in out-of-focus and a double laser pulse scheme characterized by crossed light polarizations. In the new system droplet images are reduced to a string by simply using a slit in front of the CCD detection optics. This scheme has the advantage of being very simple and affordable. We will discuss the advantages of such an approach in the characterization of dense particle systems when compared to the standard out-of-focus set-up

The new GSI arrangement permits to measure two components of the velocity of each particle simultaneously to its diameter. The new approach is named GSI-V. Size and velocity of droplets in a spray were determined by using GSI-V technique. In the paper particular emphasis is devoted to the study of small particles (with diameters below 20 μm). To this aim, the new scheme was also applied to study evaporating binary mixtures. The experimental results concerning both the applications will be discussed in the paper.

2. EXPERIMENTAL SET-UP

Two main features characterize the innovative scheme GSI-V. The first concerns the use of a slit in front of the detection optics and serves to extend the application of the GSI technique to systems with higher particles concentration. In fact, in out of focus condition the size and shape of the defocused droplet image is determined by the detection optics that delimits the observation field. Thus, when the slit is used as stop, the circular images are reduced to linear strings. This reduces the incidence of superimposition of images and hence, the counting rate increases permitting the application of GSI technique to moderately dense sprays. In fact, images of droplets that are superimposed in the standard “full image” configuration appear as a collection of separate strings by using the new optical configuration (Fig. 2).

The second novelty consists in the use of a double laser pulse scheme in order to infer droplets velocity by means a time of flight approach. Peculiar characteristic of the proposed system is the utilisation of two laser pulses having orthogonal light polarisations. The first one was vertically polarised and used to determine the size of droplets. The second beam, horizontally polarised, was delayed respect to the vertical polarised one and serves to define the position of droplets after the elapsed time. Velocity of droplets is inferred by measuring the position shift of the droplets images corresponding to the two laser pulses. The main characteristic permitting to distinguish between out of focus images generated by the two orthogonal polarisation pulses is the oscillations “visibility” η (i.e., the contrast between maxims and minima in the oscillating signal). Out of focus strips generated by H and V polarized beams own a visibility of 0.2

and 0.9 (Calabria and Massoli, 2001), respectively, and thus are easily recognized. Therefore, images analysis is really simplified, false doublets eliminated, and the velocity is unambiguously determined.

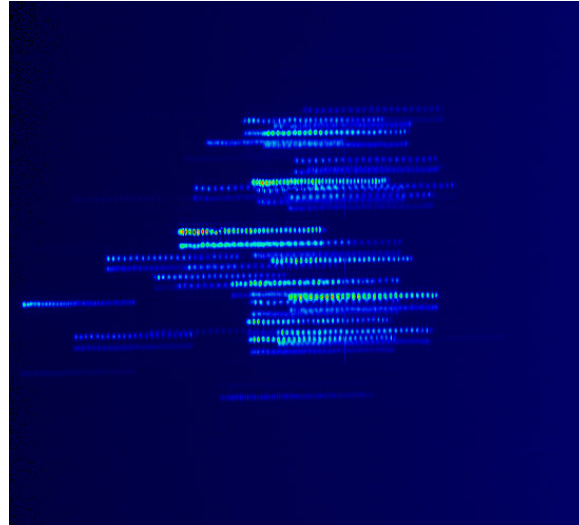

Fig.2 GSI out-of-focus image of a group of droplet.

Figure 3 shows the layout of the experimental set-up. Two Nd-Yag laser pulses @ $\lambda=532$ nm of equal intensity and orthogonal polarizations were delayed by means a variable delay generator. The beams were superimposed by using a polarising beam splitter. The energy of the pulses, 8 ns short, was balanced to the same value of about 70 mJ. Both the laser beams were reduced in the measure volume to a sheet 100 μ m thin by a cylindrical lens. The first laser pulse was vertically polarised, the second one was horizontally polarized. The imaging system captured images of droplets passing through the double light sheet in the probe volume. The CCD (1024x1024 pixels square array, 12/16 bit fast/slow data transfer) was placed at a scattering angle of 60° . A slit of 250 μ m was used to reduce the circular out-of-focus images in “string” images.

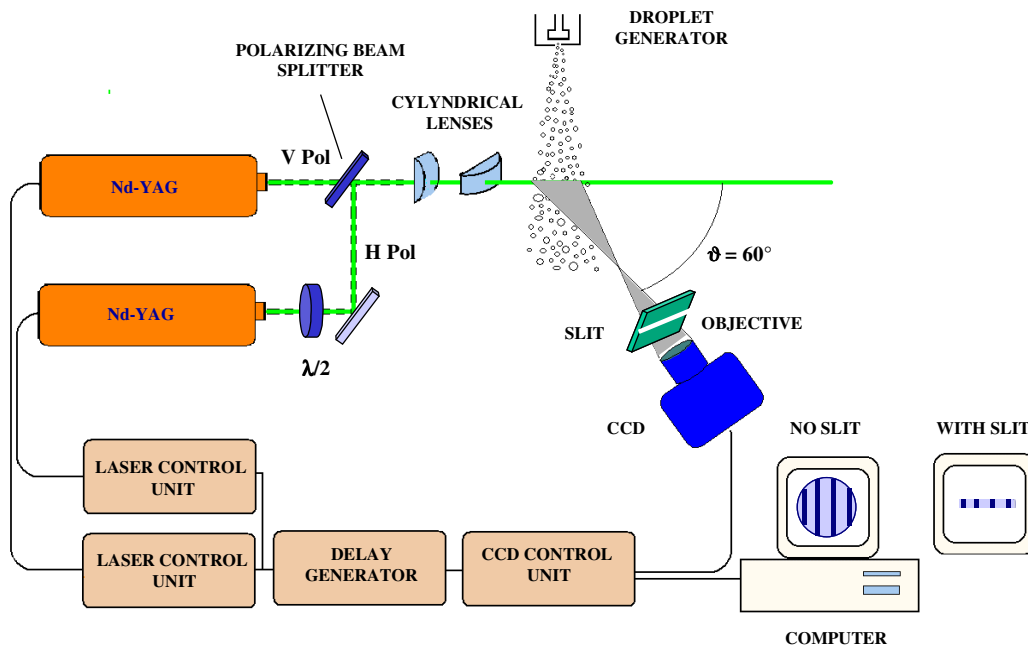

Fig. 3 Experimental set-up.

Figure 4 shows a typical image recorded during the experimental campaign and also explains the data reduction procedure. False doublets corresponding to different droplets are easily individuated by means the visibility criterion. Relation (1) is used to determine the sizes of droplets; the velocity components are inferred by measuring the droplets displacements Δx and Δy . Δt is the time between the two laser pulses.

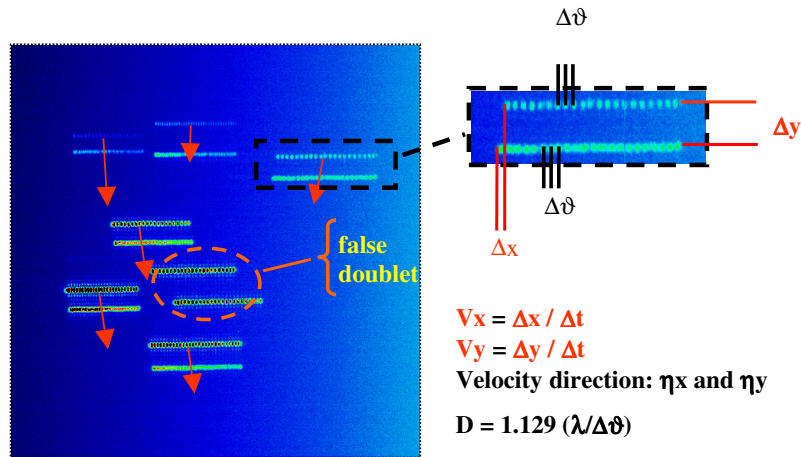

Fig. 4 GSI-V out of focus image doublets of water droplets of $70 \mu\text{m}$. Each doublet of strings corresponds to a single droplet. Also the velocities are represented in the picture.

3. SELECTED RESULTS

3.1 Velocity and Diameter of Droplets in a Spray

GSI-V technique was utilised to measure the velocity and diameter of droplets in a water spray. Figure 5 shows a particular of the system utilised in the experimental tests. Droplets were generated by using a Berglund-Liu generator (Berglund and Liu, 1973) (TSI 3450 vibrating orifice). A dispersion air rate of 1750 cc/min was used to avoid droplets coalescence. The orifice was $50 \mu\text{m}$ and the break-up frequency was set at 16,57 kHz. Distilled water was utilised in the tests. The droplets generator head was placed on an air distributor and the spray downstream directed. The spray was injected in a coaxial secondary air flux. In order to uniform the air flow the adduction port to the distributor was tangential and a grid of small tubes were used. A cylinder, 40 mm I.D., confined the gaseous flux.

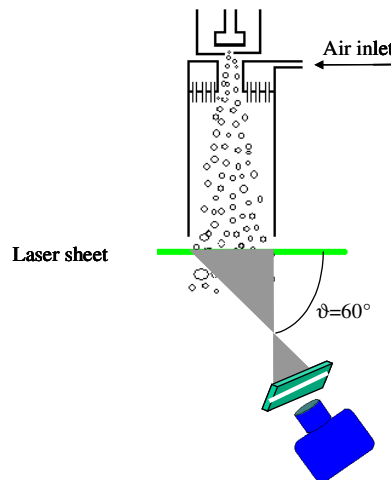

Fig. 5. Particular of the arrangement utilised in the spray tests

The imaging system was placed in out of focus position and at the scattering angle of 60° . Size and velocity of each droplet passing in the measure section, at the exit of the cylindrical section, were simultaneously measured. The measurements were carried out for different secondary flow rates exactly at the same spatial location. Analysing the out of focus picture, diameter and velocity of droplets were determined as explained in the previous section. Figure 6 reports the velocities measured along the measurement section. In the picture, a zero radial position corresponds to the axis of the cylindrical section. Every vector is obtained by averaging the vector droplet velocities measured on a region $4\text{mm} \times 2\text{mm}$ ($W \times H$). On the same picture also the corresponding mean droplets diameters are reported. They represent the mean values of the diameters measured on the same droplets ensembles utilised for velocity measurements.

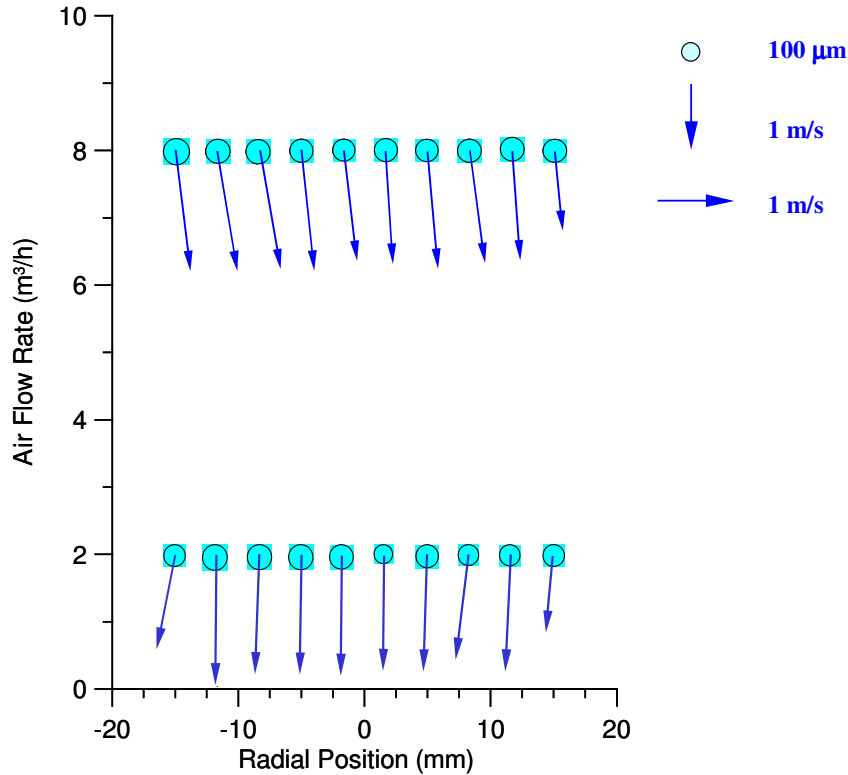

Fig.6. Mean droplets velocities and diameters measured by using GSI-V technique in a downstream water spray for two secondary coaxial flow rates. Zero radial position corresponds to the spray axis. The reported values represent the average of the vector droplet velocities and diameters measured on spatial regions $4\text{mm} \times 2\text{mm}$ ($W \times H$) at the exit of the tubular confining section.

3.2 Diameters of Evaporating Binary Mixture Droplets

In dedicated experiments GSI technique was applied to study droplets with diameter smaller than $20\ \mu\text{m}$. In this series of tests calibrated droplets of $44\ \mu\text{m}$ of binary mixtures were injected in a heated air flow. The experimental system was the same utilized in tests described in the previous paragraph but with the secondary air heated at 52°C . The mixtures were composed of isopropyl alcohol and tetradecane in different volume proportions: 0.75%, 1.5%, 3%, 5.2% and 12.5%. The Berglund-Liu atomizer was used to generate monodisperse sprays. The generator operated to produce droplets of the same size in all tests. Due to the large difference in boiling temperatures of the mixture components (252°C and 82°C for tetradecane and isopropyl alcohol, respectively) it was possible to set the length of the heating section in order to completely vaporize alcohol excluding significant evaporation of tetradecane. In all experiments, droplets diameters were measured in the same spatial location at the exit of the cylindrical section. On the basis of alcohol content in the parent mixture, the expected diameter of tetradecane droplets after alcohol evaporation were $8.8\ \mu\text{m}$, $11.0\ \mu\text{m}$, $13.9\ \mu\text{m}$, $16.7\ \mu\text{m}$, and $22.3\ \mu\text{m}$, respectively.

GSI equation (1) permits size measurements of droplets as small as $5\ \mu\text{m}$ with an uncertainty of about 4% also for marked variations of the refractive index. Thus, it is suitable for the sizing of droplets undergoing variation of composition and/or temperature as in the case under study. However, other two aspects have to be preliminary faced in order to assess a friendly use of GSI technique to small droplets. The first concerns the visibility of intensity oscillations that corresponds to a reliable experimental detection of oscillations. The second one regards the dependence of the scattered light on droplet diameter and implies the possibility of studying large distributions of diameters with the same setting of the optical systems. Generally speaking, the scattering behavior of small droplets strongly differs from large droplets in terms of effects and of quantity. It should be underlined that the concept of small and large droplets is relative and depends on the aspects under study, which in turn imply size and properties of droplets, polarization of light and scattering angle. For example, Massoli et al. (1989) showed that at a scattering angle of 90° a water droplet scatters horizontal polarized light with the second power of the diameter when the diameter is as large as $600\ \mu\text{m}$. On the contrary, for vertically polarized light the D^2 scattering behavior is attained already at $D=10\ \mu\text{m}$. The scattering with a D^2 law is the behavior of droplets in geometrical optics regime, thus it could be used as roughly method for defining large droplets. In GSI technique the scattering angle is smaller, $\vartheta=60^\circ$; thus the characteristic behavior of large droplets should be attained for smaller droplets respect to the case at $\vartheta=90^\circ$. In order to qualify the raised question, Figures 7-9 report the mean values of angular spacing, visibility and maxims of the scattered intensity oscillations of water droplets ($n=1.334-i10^{-6}$) smaller than $20\ \mu\text{m}$. The data represent the average on the scattering angular aperture $\vartheta=60^\circ\pm 10^\circ$. It appears that with a CCD with a dynamic range covering three orders of magnitude and with an angular aperture of the detection optics of $\pm 10^\circ$ it is possible to measure the size of droplets from $50\ \mu\text{m}$ down to few microns by using GSI technique. From picture 8 it appears that mean visibility of oscillations is always high, between 0.6 and 0.9, this meaning a good individuation and detection of oscillations.

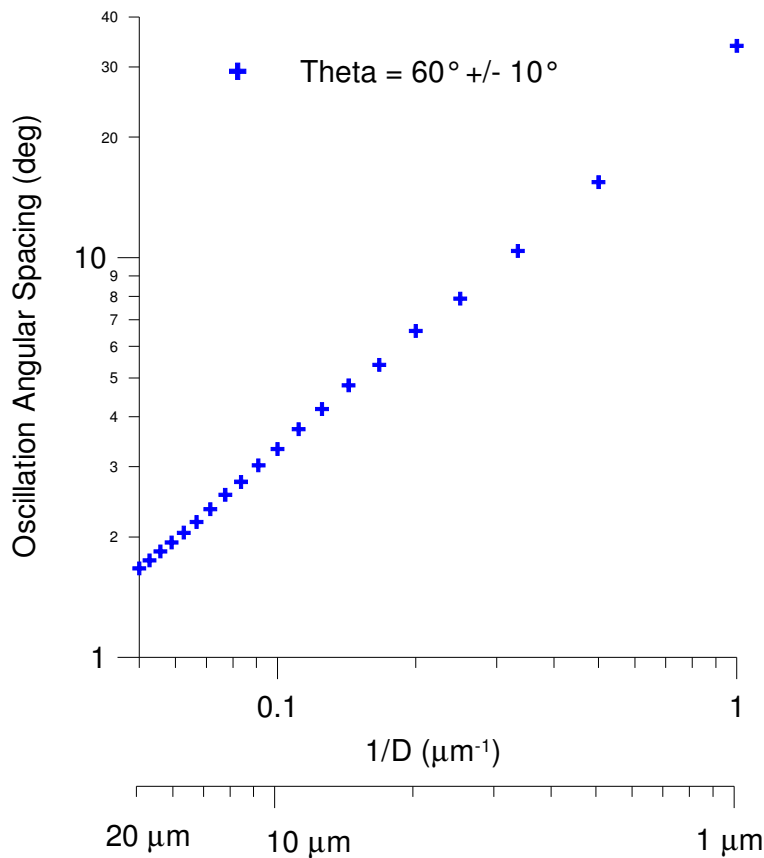

Fig. 7. Mean angular spacing of intensity oscillations vs. diameter for water droplets at $\vartheta=60^\circ$.

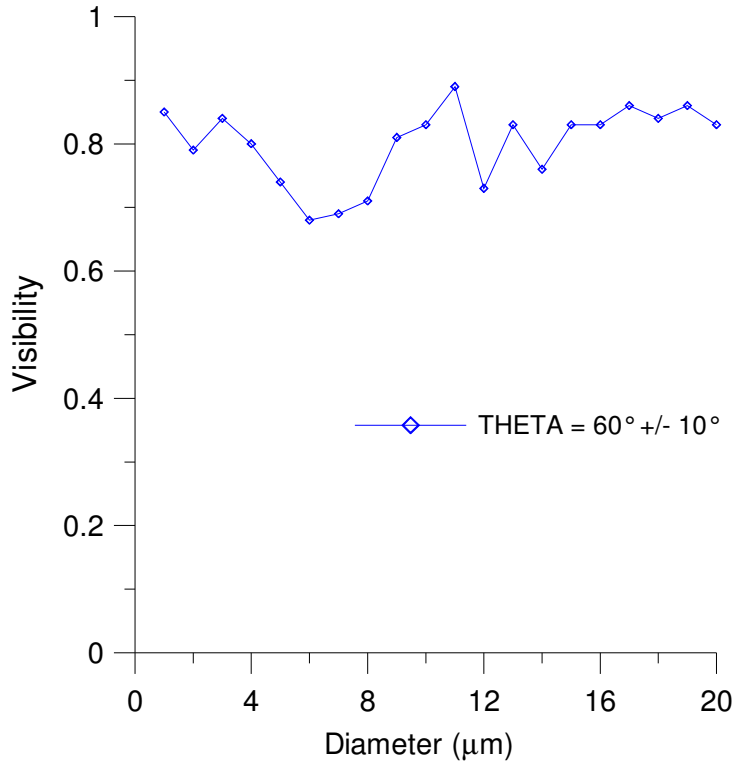

Fig. 8. Mean visibility of intensity oscillations vs. diameter for water droplets at $\vartheta=60^\circ$.

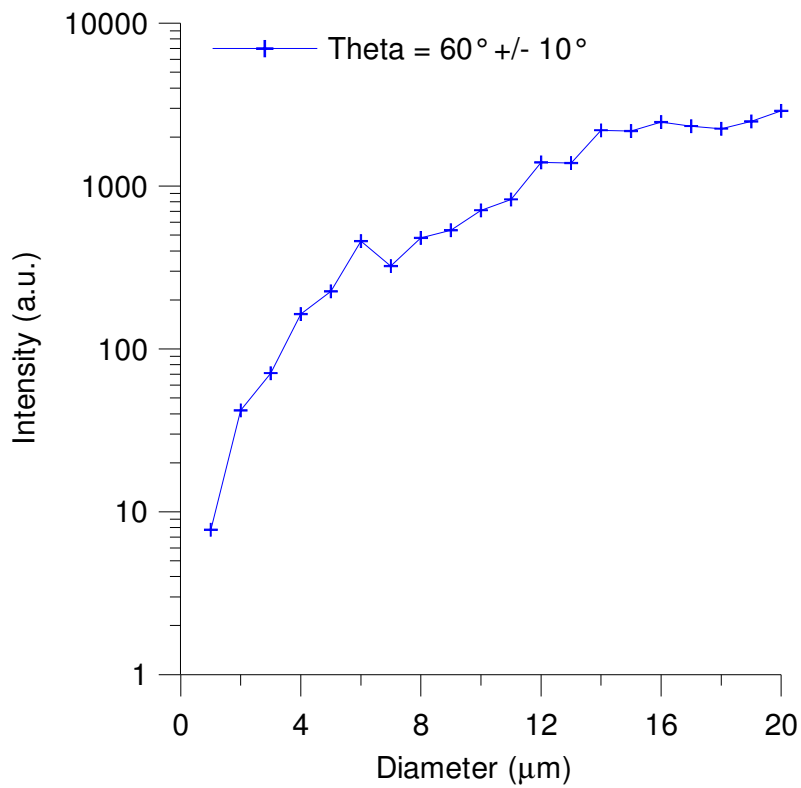

Fig. 9 Mean values of maxims of intensity oscillations vs. diameter for water droplets at $\vartheta=60^\circ$.

Preliminary tests were carried out to verify the extent of tetradecane evaporation. The results are presented in Fig. 10 that shows the diameter distributions of tetradecane droplets at room temperature and 52 °C, respectively. Mean diameters were very similar in both conditions. However, a redistribution of diameters around the mean value was observed in the heated spray. This could be due to two opposite effects caused by droplets heating: a light evaporation in a direction and a volume expansion in the opposite direction. Such a broadening behavior, even if in presence of a more marked evaporation, was observed during the first phases of burning heptane droplets (Calabria et al., Sorrento 2003a). However, in the present case, the vaporization of alcohol should take droplet lightly cool and distribution broadening partially balanced.

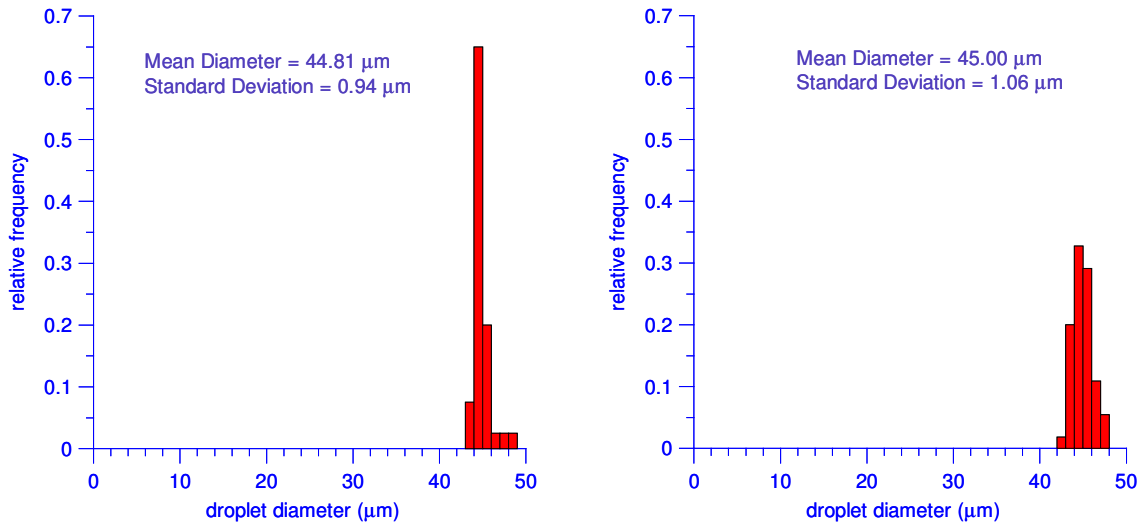

Fig. 10. Size distributions of tetradecane droplets measured at room temperature (left) and 52 °C (right).

Figures 11 reports the size distributions of mixtures droplets after the alcohol evaporation at the exit of the heating section. The measured mean droplets diameters are in nice agreement with the diameters of tetradecane droplets expected at exit the heating section after complete alcohol evaporation. This point is qualified in picture 12 where the measured mean droplets diameters are reported in function of the expected ones.

4. FINAL REMARKS

A new scheme for GSI out-of-focus technique able to simultaneously measure size and velocity of droplets is presented and the basic principles discussed. The new approach, GSI-V, is based on a single CCD and a double laser pulse with crossed polarization. In the proposed system a slit is used in front of the detection optics to reduce large circular out-of-focus images to thin strings. This together the crossed polarizations of the laser pulses permit the application of GSI-V to moderately dense droplets systems. The application of GSI-V to measure size and velocity of a water spray droplets is discussed. A theoretical analysis concerning the application of the out-of-focus method to small droplets is outlined. In dedicated experiments GSI approach was applied successfully to binary evaporating droplets as small as 7 μm. In the future, efforts will be spent to extend the application of GSI technique to irregular particles and to droplets below 5 μm.

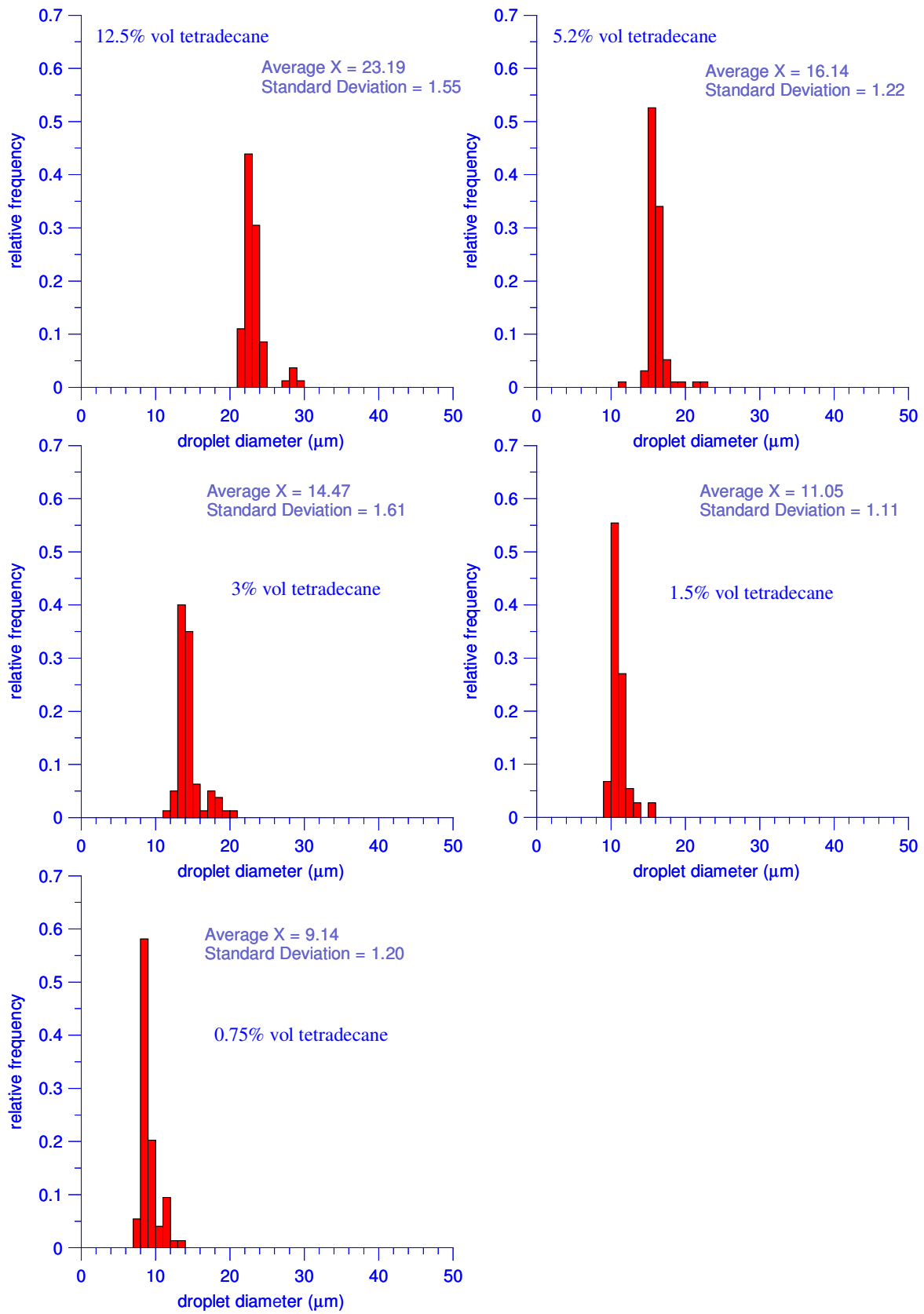

Fig. 11. Measured size distributions of mixtures droplets after the alcohol evaporation.

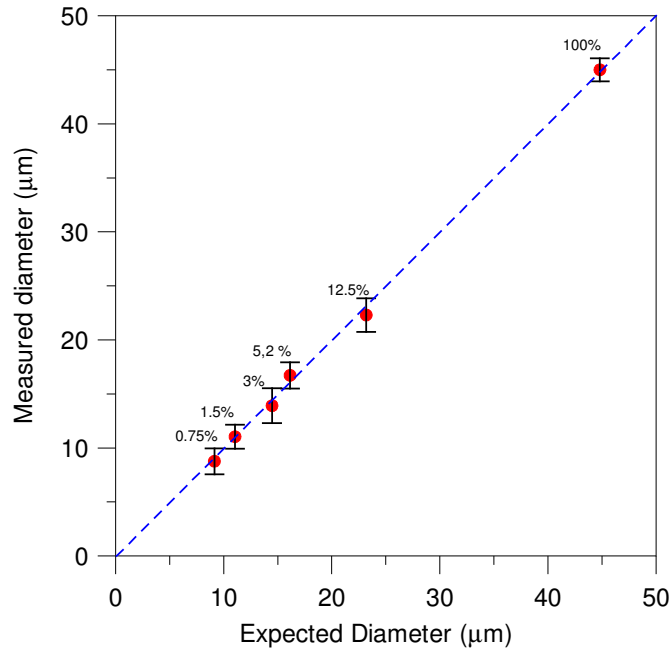

Fig. 12. Mean values of measured diameters distributions vs. the expected diameters for the different mixtures.

REFERENCES

- Bartholdi, M., Salzman, G.C., Hiebert, R.D., and Kerker, M., (1980). *Appl. Opt.*, 19, pp. 1573-1581.
- Berglund, R.N. and Liu, B.Y.H. (1973). *Environ. Sci. Technol.*, 7, pp.147.
- Calabria, R., and Massoli, P. (2000). Proc. 10th Intl. Symp. On Appl. Of Laser Techniques to Fluid Mechanics, July, 10th-13th, Lisbon Portugal.
- Calabria, R. and Massoli, P. (2001). Proc. 17th Conf. on Liquid Atomization and Spray Systems, ILASS-Europe, July, 2nd-6th, Zurich Switzerland.
- Calabria, R., Casaburi, A. and Massoli, P. (2003a, paper 10.6). Proc. 9th Int. Conf. on Liquid Atomization and Spray Systems - ICLASS 2003, July, 13th-17th, Sorrento Italy.
- Calabria, R., Casaburi, A. and Massoli, P. (2003b, paper 7.7). Proc. 9th Int. Conf. on Liquid Atomization and Spray Systems - ICLASS 2003, July, 13th-17th, Sorrento Italy.
- Calabria, R., Esposito, B. and Massoli, P. (2004). Proc. 12th Intl. Symp. On Appl. Of Laser Techniques to Fluid Mechanics, July, 12th-15th, Lisbon Portugal.
- Damaschke, N., Nobach, H., Nonn, T. I., Semidetnov, N. and Tropea, C. (2002). Proc. 11th Intl. Symp. On Appl. Of Laser Techniques to Fluid Mechanics, July, 8th-11th, Lisbon Portugal.
- Davis, E.J. and Schweiger, G., (2002). "The airborne microparticle", Springer .
- Glover, A.R., Skippon, S.M. and Doyle R.D. (1995). *Appl. Opt.*, 34, pp. 8409-8421.
- Grassman, A. and Peters, F. (2003). "Size measurement of very small spherical particles by Mie Scattering Imaging (MSI)", submitted for publication on Particle and Particle Systems Characterisation.
- Kerker, M., (1969). "The Scattering of Light and Other Electromagnetic Radiation", Academic Press.

Kobayashi, T., Kawaguchi, T. and Maeda, M. (2000). Proc. 10th Intl. Symp. On Appl. Of Laser Techniques to Fluid Mechanics, July, 10th-13th, Lisbon Portugal.

Koch, A., Schmidt, V. and Oschwald, M. (2001). Proc. 17th Conf. on Liquid Atomization and Spray Systems, ILASS-Europe, July, 2nd-6th, Zurich Switzerland.

König, G., Anders, K. and Frhon A. (1986). J. Aerosol Sci., 17, pp.157-167.

Krüger, S., and Grünfeld, G. (2001). Proc. 17th Conf. on Liquid Atomization and Spray Systems, ILASS-Europe, July, 2nd-6th, Zurich Switzerland.

Massoli, P., Beretta, F. and D'Alessio, A. (1989). Appl. Opt., 28, pp.1200-1205.

Massoli, P., and Calabria, R., (1999). Proc. 15th Conf. on Liquid Atomization and Spray Systems, ILASS-Europe, July, 5th-7th, Toulouse France.

Min, S.L., and Gomez, A., (1996). Appl. Opt., 35, pp. 4919-4926.

Pajot, O. and C. Mounaïm-Rousselle (1998). Proc. 9th Intl. Symp. On Appl. Of Laser Techniques to Fluid Mechanics, July, 13th-16th, Lisbon Portugal.

Ragucci, R., Cavaliere A. and Massoli P. (1990). Part. Part. Syst. Charact., 7, pp. 221-225.